



CELETTE[®]

CAR LIFE SOLUTIONS



CARROSSERIE SERVICE
RICHT- EN LAS APPARATUIR - EQUIPMENTS DE REDRESSAGE ET SOUDAGE



SYSTEM MZ

*L'outil qui contrôle & maintient
The jig system to hold, check and locate*

Référence sur demande / Part number upon request

Le système de contrôle positif MZ homologué par les plus grands constructeurs automobile mondiaux est :

- simple et précis
- un outil de réparation de qualité, égal à ceux utilisés sur les lignes de montage des véhicules
- une aide indispensable et nécessaire aux techniciens évitant tout risque d'erreurs
- idéal pour tous travaux de reconstruction

The MZ jig system, homologated by the world leading car manufacturers :

- is an accurate tool based on a fixture system which are used on the car production line
- eliminates operator error (no guess work)
- ideal for any structural repairs

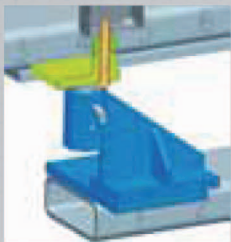

*Utilisation sans mécanique
Without mechanical use*

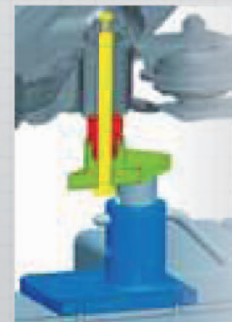
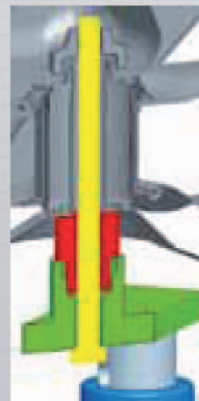

*Utilisation avec mécanique
With mechanical use*

*Le contrôle peut s'effectuer sur tous les marbres CELETTE mécanique en place ou mécanique déposée.
Checking may be completed on all CELETTE benches, with or without mechanical.*

SYSTEM MZ

L'outil qui contrôle & maintient
The jig system to hold, check and locate



CARROSSERIE SERVICE
 RICHT- EN LAS APPARATUUR - EQUIPMENTS DE REDRESSAGE ET SOUDAGE

Référence sur demande / Part number upon request



XXX.3XX



MZ450.925

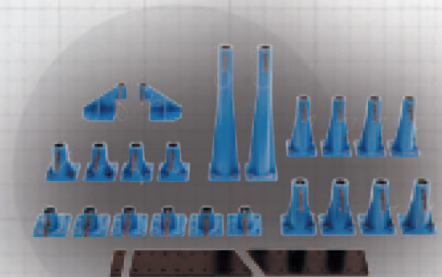

MZ450.010



955.908

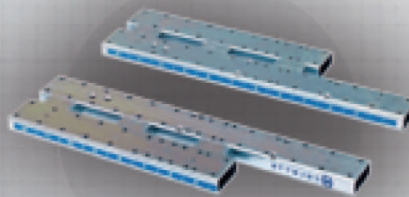

955.9052



955.915

Références / part number	Description
MZ450.925	Jeu de 22 tours MZ + 2 cales TV 410 + servante de rangement <i>MZ 22 towers + 2 wedges TV 410 + Storage trolley</i>
MZ450.010	Jeu de tours MZ <i>Set of MZ towers</i>
955.915	Servante de rangement + 5 traverses modulaires <i>Storage trolley + Set of 5 modular crossmembers</i>
955.908	Traverse supplémentaire C3 <i>Complementary crossmembers C3</i>
955.9012	Jeu de 5 traverses modulaires <i>5 crossmembers set</i>
955.9052	2 Traverses spéciales Mercedes <i>2 Mercedes crossmembers</i>
955.9052	2 Traverses spéciales Mercedes <i>2 Mercedes crossmembers</i>

SYSTÈMES DE MESURE / MEASURING SYSTEM

Retrouvez les fiches MZ, MZ+ en téléchargement sur notre site.
 The MZ, MZ+ data sheets are available for downloading on our web site.





CELETTE[®]

CAR LIFE SOLUTIONS

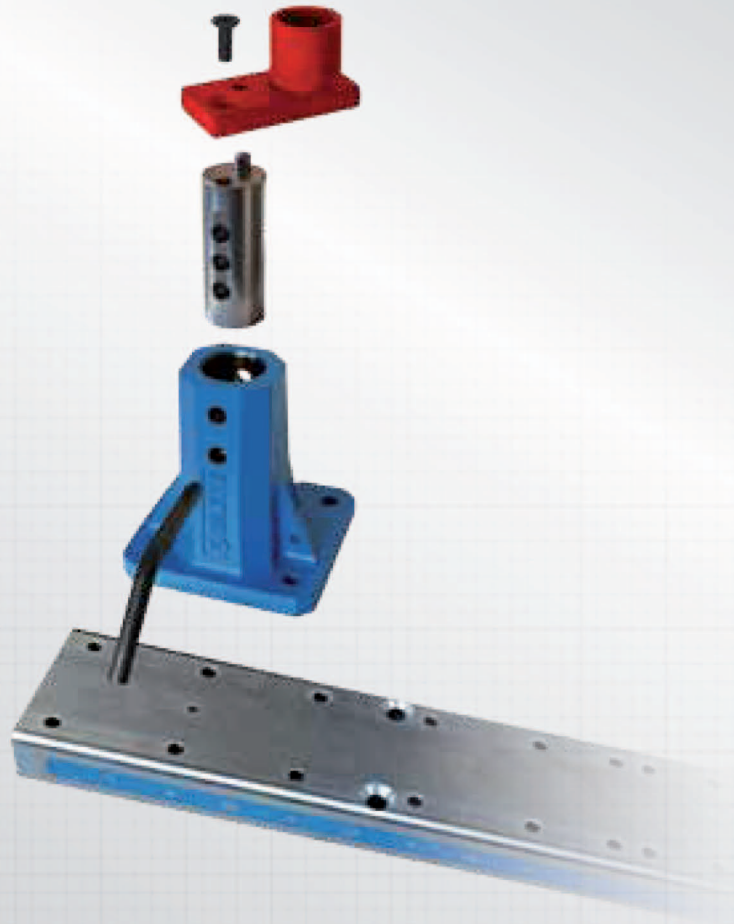

SYSTEM MZ+

Tour + piston + tête = La bonne opération
Tower + piston + top = The right combination

Référence ferrures par marque sur demande / Part number for MZ top by car type upon request

Le System MZ+ est l'évolution du System MZ, simple rapide et précis, il contrôle et maintient. Seules les têtes MZ+ restent spécifiques.

System MZ+ is an evolution from the MZ system. Simple, rapid and accurate for holding and positioning. The modular crossmembers, MZ towers and pistons are universal. The MZ+ tops are vehicle specific.



CARROSSERIE SERVICE
RICHT- EN LAS APPARATUUR - EQUIPMENTS DE REDRESSAGE ET SOUDAGE

SYSTEM MZ+

Tour + piston + tête = La bonne opération

Tower + piston + top = The right combination

Référence ferrures par marque sur demande / Part number for MZ top by car type upon request



Mise en contact ou dégageage instantané des têtes MZ
Instantaneous contact or disconnection of MZ Tops

Comme avec le système MZ, le contrôle peut s'effectuer sur tous les marbres CELETTE mécanique en place ou mécanique déposée.
Like the MZ system, checking may be done on all CELETTE benches, with or without mechanical units.



2xxx.5xx

Jeu de têtes MZ + avec rangement
spécifique pour visserie
Specific storage for MZ system tops



MZ2500.000



Jeu de 34 pistons universels
Set of 34 universal pistons

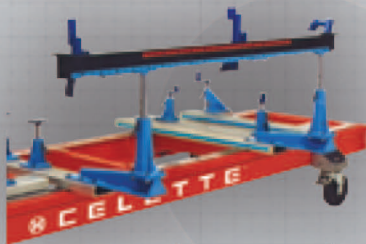

9113.063

Portique de contrôle des côtés de
caisse

Overhead gantry for checking
side and upper panels of the car-
body



Jeu de 22 tours MZ
Set of 22 MZ towers

MZ450.010



CARROSSERIE SERVICE
RICHT- EN LAS APPARATUUR - EQUIPMENTS DE REDRESSAGE ET SOUDAGE

Retrouvez les fiches MZ, MZ+ en téléchargement sur notre site

The MZ, MZ+ data sheets are available for downloading on our web site.

© Copyright CELETTE SA. Photos non contractuelles - Reproduction interdite / All modifications reserved - All rights reserved

Doc.409 F-GB/R2 05/10



SYSTEMES DE MESURE / MEASURING SYSTEM

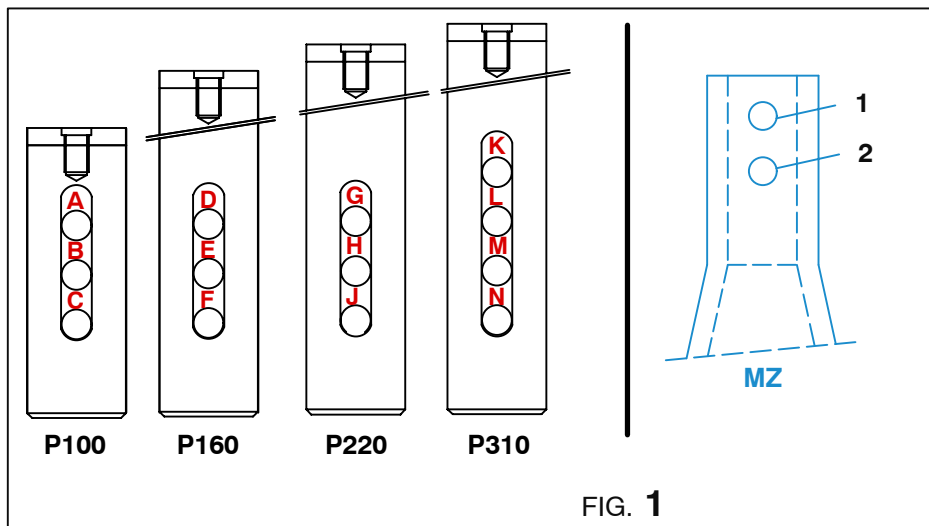
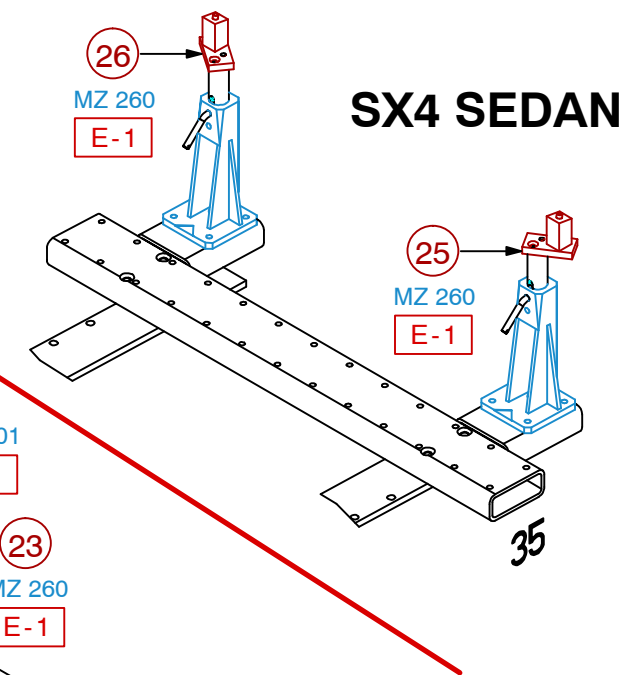
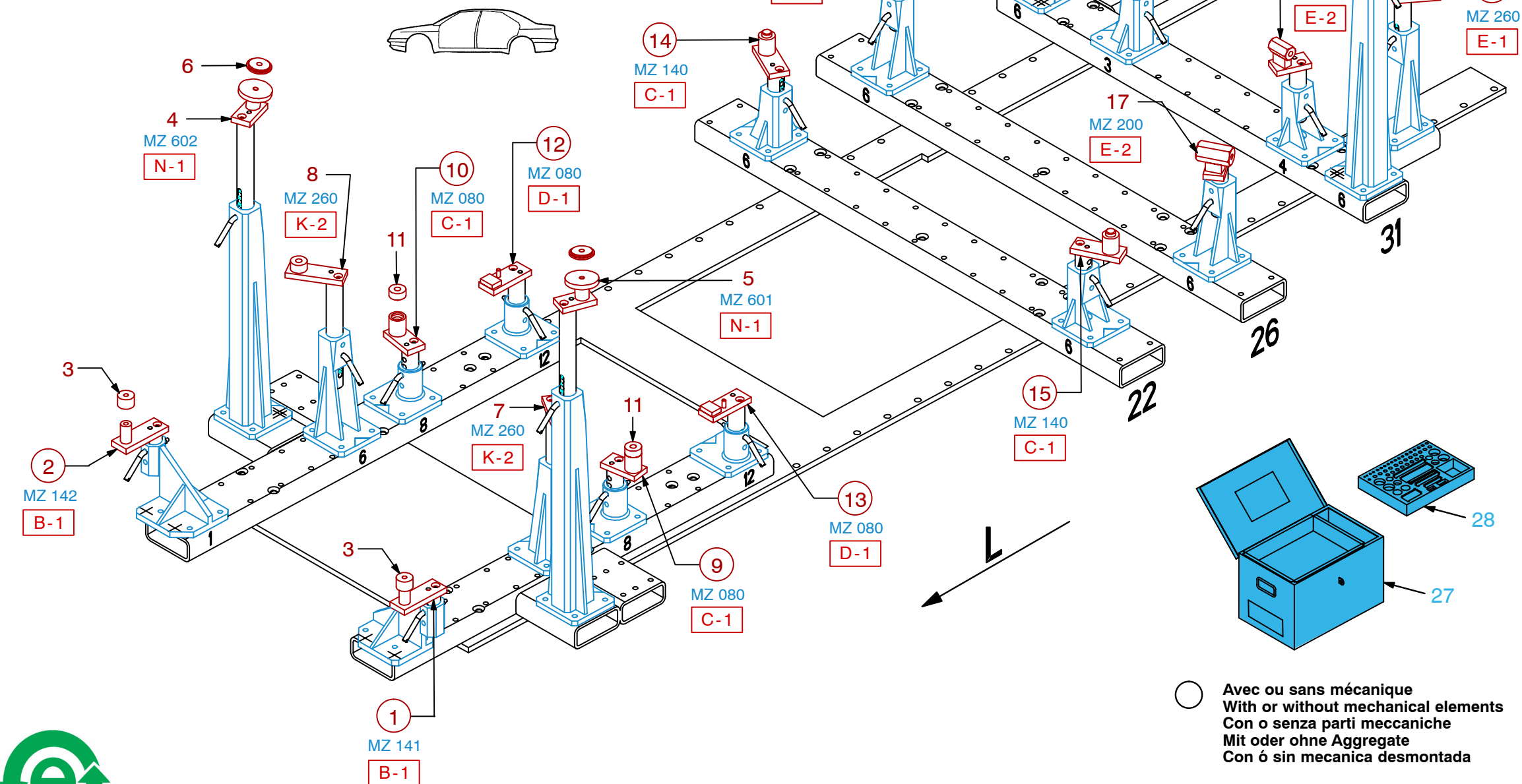

FIG. 1



REP.	REFERENCE	PDS	NB	PISTON	MZ
1	2511.5001	0,9	1	P100	141
2	2511.5002	0,9	1	P100	142
3	2511.5003	0,2	2		
4	2511.5004	1,0	1	P310	602
5	2511.5005	1,0	1	P310	601
6	2511.5006	0,3	2		
7	2511.5007	0,9	1	P310	260
8	2511.5008	0,9	1	P310	260
9	2511.5009	0,8	1	P100	080
10	2511.5010	0,8	1	P100	080
11	2511.5011	0,2	2		
12	2511.5012	0,8	1	P160	080
13	2511.5013	0,8	1	P160	080
14	2511.5014	1,1	1	P100	140
15	2511.5015	1,1	1	P100	140
16	2511.5016	1,7	1	P160	200
17	2511.5017	1,7	1	P160	200
18	2511.5018	1,0	1	P160	140
19	2511.5019	1,0	1	P160	140
20	2511.5020	0,6	1	P160	602
21	2511.5021	0,6	1	P160	601
22	2511.5022	0,1	2		
23	2511.5023	1,2	1	P160	260
24	2511.5024	1,2	1	P160	260
25	2511.5025	1,1	1	P160	260
26	2511.5026	1,1	1	P160	260
27	MZ2500.CR500B	6,5	1		
28	MR.2511.500	0,2	1		

- M 12-25
- M 10x1,25-110
- M 14x1,50-60
- M 14x1,50-100

○ Avec ou sans mécanique
 With or without mechanical elements
 Con o senza parti meccaniche
 Mit oder ohne Aggregate
 Con ó sin mecanica desmontada

FIAT / SUZUKI

2511.500

31 Kg	18.09.2007	411-D-25A
2511.500-RVA3-1		00



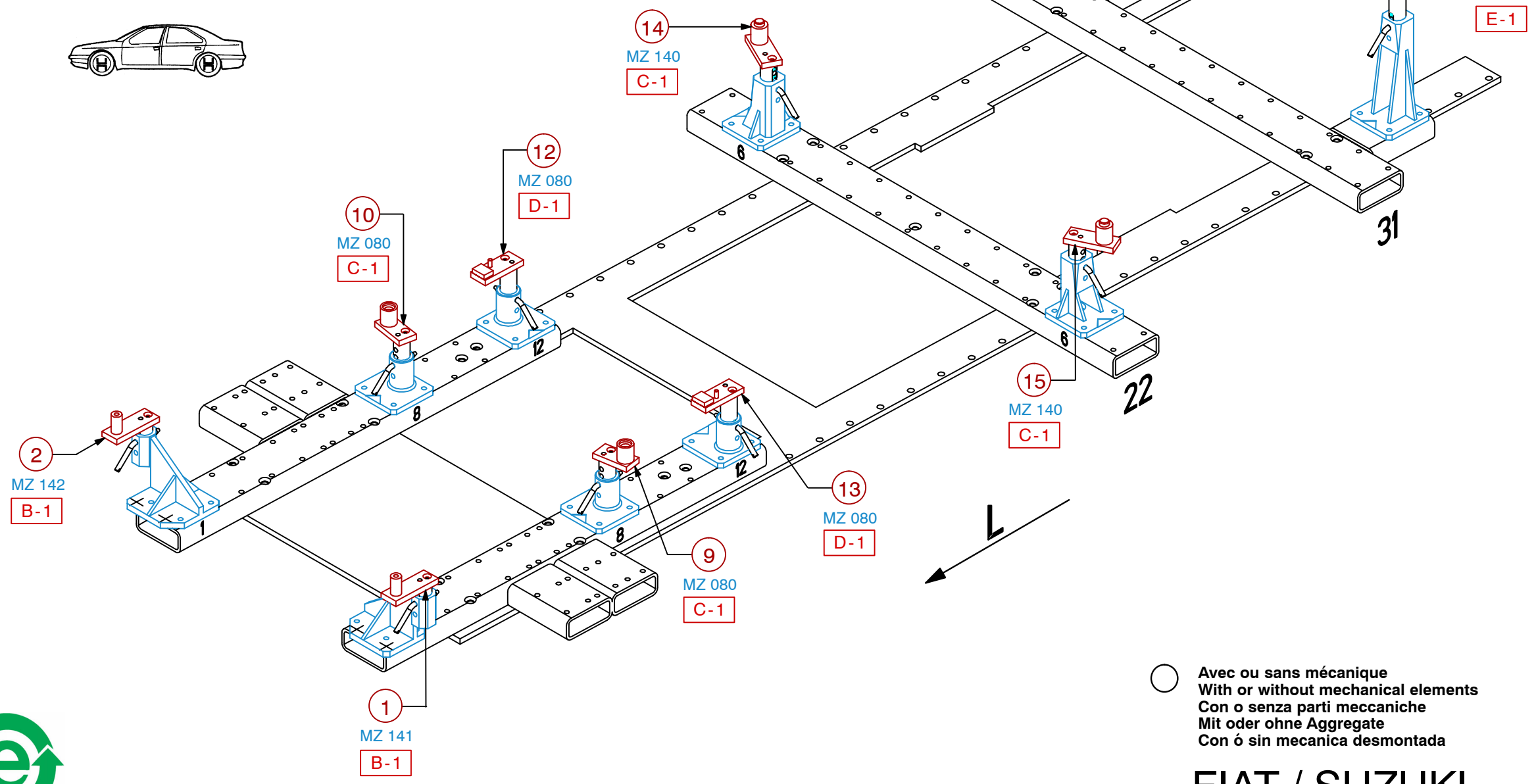
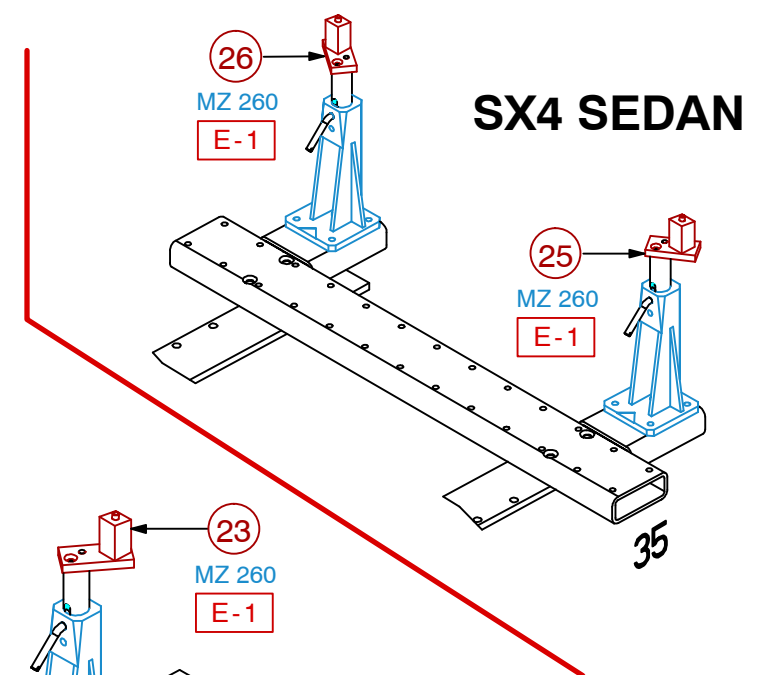
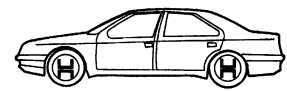
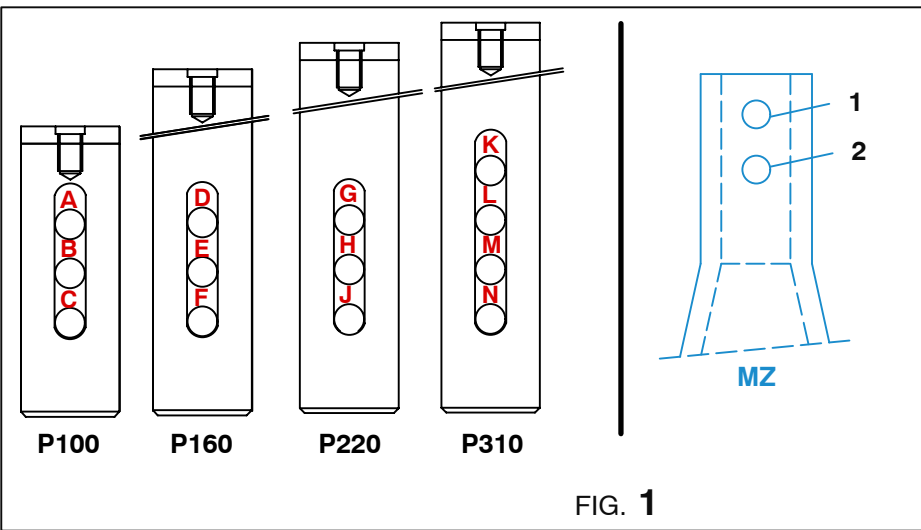

○ Avec ou sans mécanique
 With or without mechanical elements
 Con o senza parti meccaniche
 Mit oder ohne Aggregate
 Con ó sin mecanica desmontada



FIAT / SUZUKI

2511.500		
31 Kg	18.09.2007	411-D-25B
2511.500-RVA3-1		00

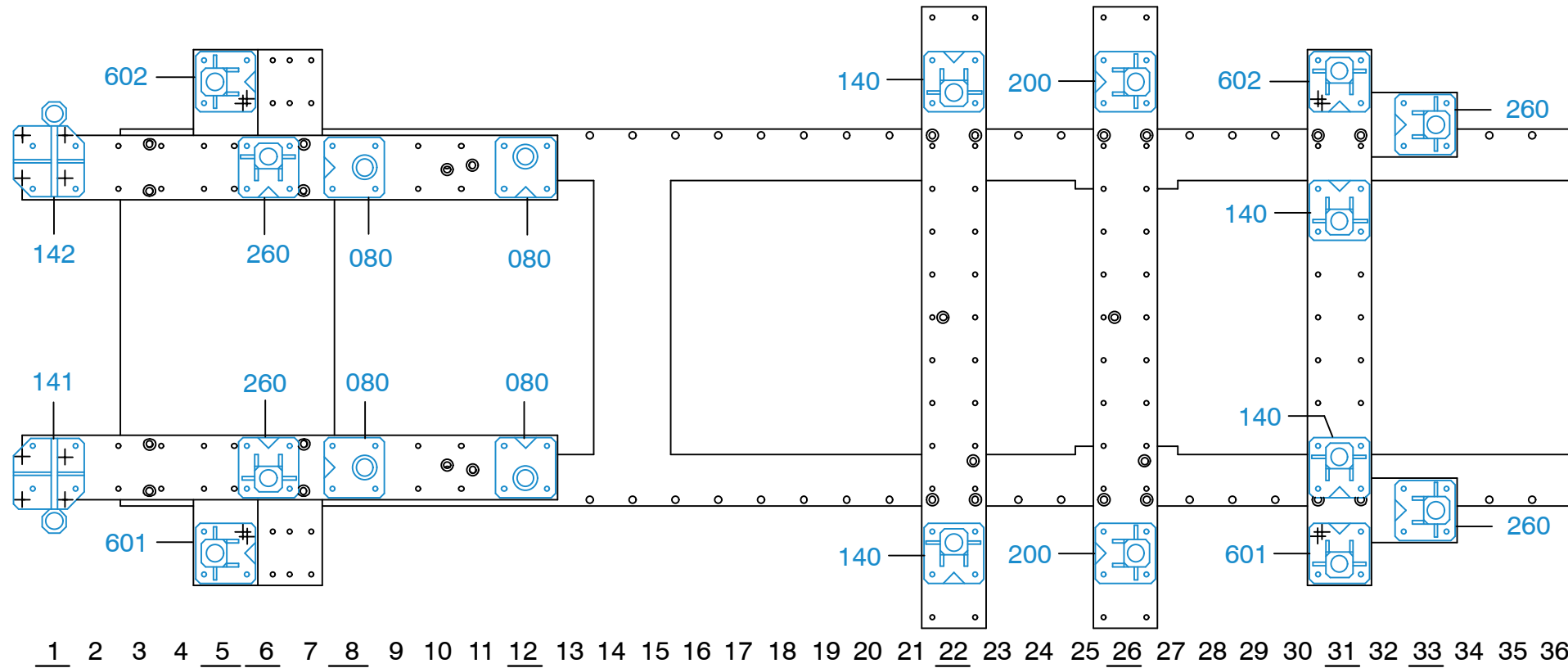
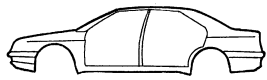

SX4 SEDAN

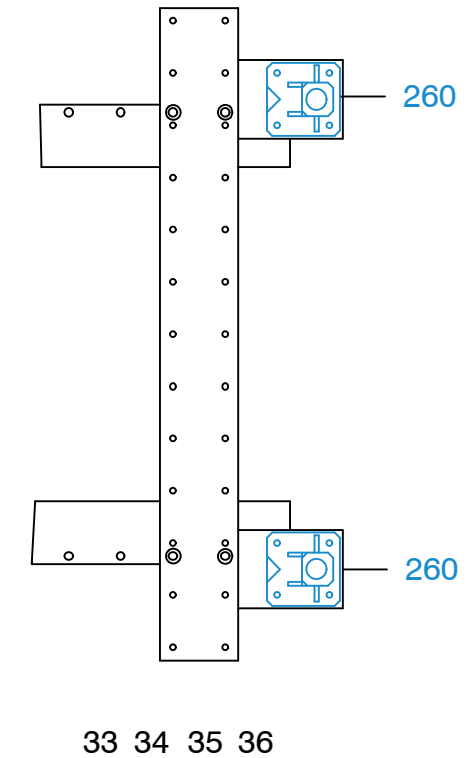

1 - 2 + 3	4 - 5 + 6	7 - 8	9 - 10 + 11	12 - 13
P100 B	P310 N	P310 K	P100 C	P160 D
MZ 141 / 142	MZ 601 / 602	MZ 260	MZ 080	MZ 080
FIG. 2	FIG. 3	FIG. 4	FIG. 5	FIG. 6

14 - 15	16 - 17	18 - 19	20 - 21 + 22	23 - 24
P100 C	P160 E	P160 E	P160 F	P160 E
MZ 140	MZ 200	MZ 140	MZ 601 / 602	MZ 260
FIG. 7	FIG. 8	FIG. 9	FIG. 10	FIG. 11

25 - 26
P160 E
MZ 260
FIG. 13

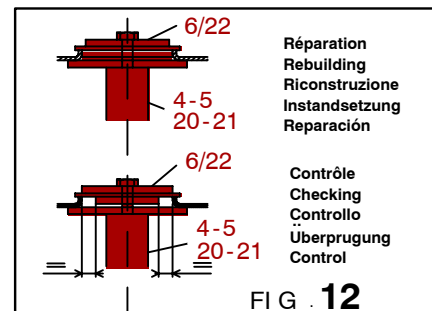

○ Avec ou sans mécanique
 With or without mechanical elements
 Con o senza parti meccaniche
 Mit oder ohne Aggregate
 Con ó sin mecánica desmontada

FIAT / SUZUKI

2511.500		
31 Kg	18.09.2007	411-D-25C
2511.500-RVA3-2		00



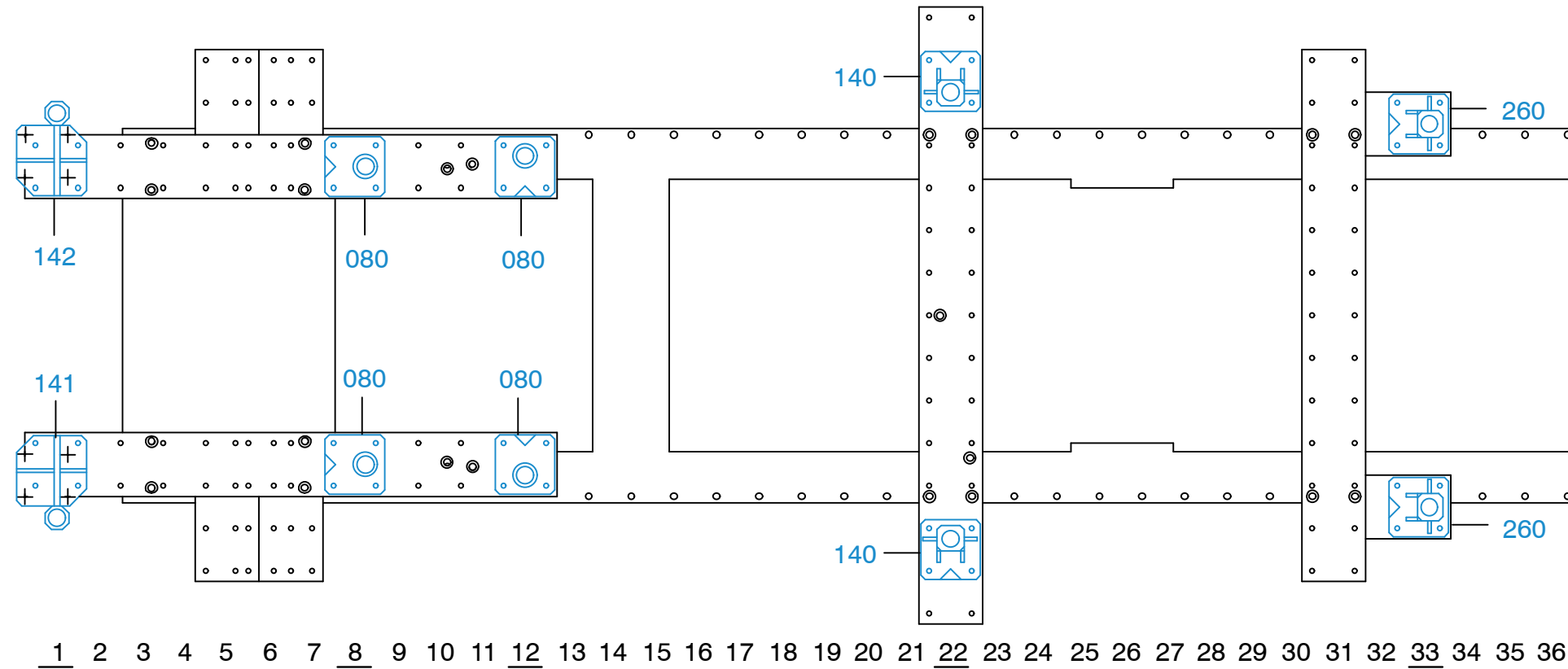

SX4 SEDAN

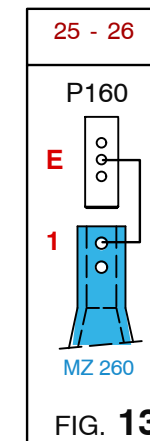
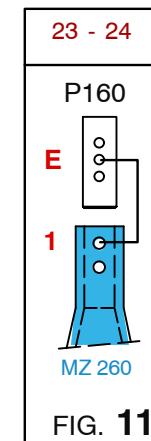
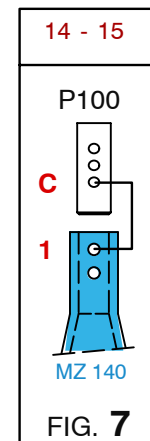
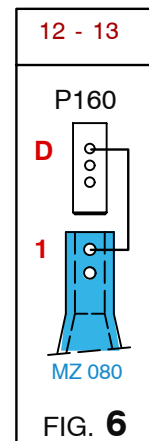
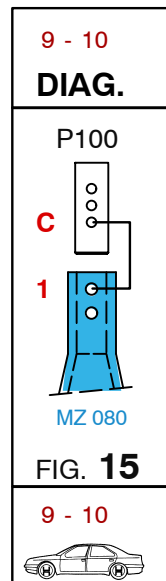
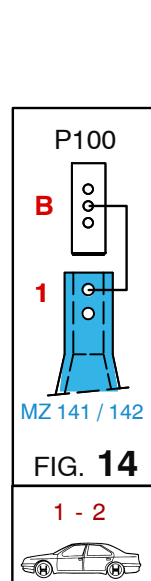
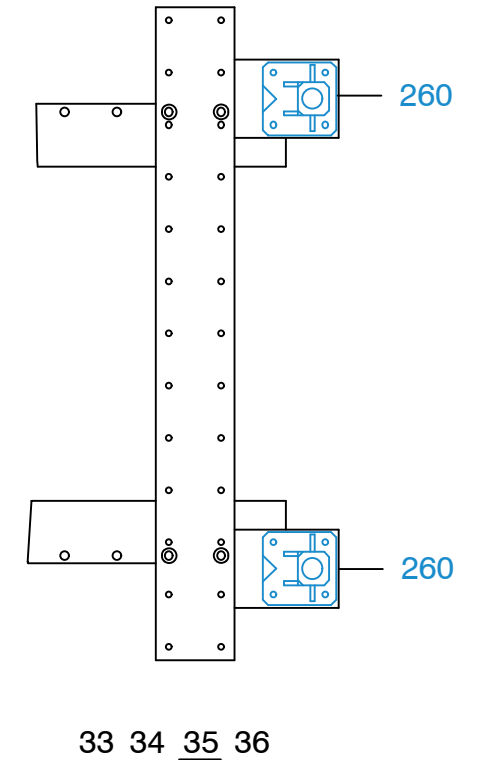

○ Avec ou sans mécanique
With or without mechanical elements
Con o senza parti meccaniche
Mit oder ohne Aggregate
Con ó sin mecanica desmontada



FIAT / SUZUKI

2511.500		
31 Kg	18.09.2007	411-D-25D
2511.500-RVA3-2		00